

- Options:**
- Bronze Handwheels ①
 - Locking Devices ②
 - Open-Shut Indicators ③

Pressures: 2100 kPa
 Steam: 1200 kPa @ 200°C

Standards: Dezincification Resistant
 BS 5154 – 1991:Globe Stop & Check Valves
 AS 3855: Materials suitable for Potable Water Service

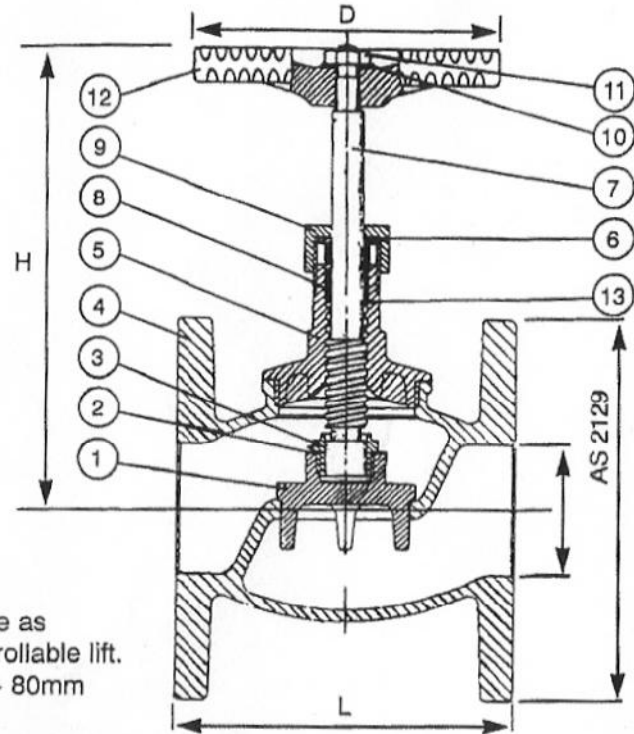

Flanges:

AS2129 Table 'D' to 'H'

④ Available: ANSI • JIS • DIN

Valve available as
 SDNR – Controllable lift.
 Sizes 25mm ~ 80mm
 Fig No T2CL

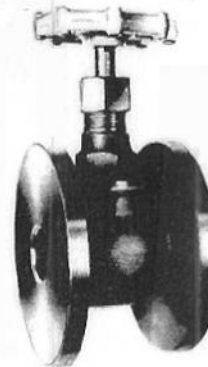
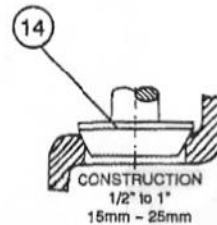

Dimensions

Size mm	8	10	15	20	25	32	40	50	65	80	100
L	•	•	70	79	89	89	105	124	165	187	
H	•	•	95	98	117	146	156	187	219	238	
D	•	•	65	65	90	90	120	150	150	190	
Wt/kgs	•	•	•	•	2.8	4.5	5.0	9.0	12.0	15.6	

ITEM	DESCRIPTION	MAT'L	STANDARD
14	DISC – SPINDLE	DR BRASS	AS1567 -352
13	SEAL RING	DR BRASS	AS1567 -352
12	HANDWHEEL	ALUM ZINC BRONZE	AS1874 AS1565
11	HANDWHEEL NUT	BRASS	
10	NAMEPLATE		
9	GLAND NUT	DR BRASS	AS1567 -352
8	GLAND PACKING	PTFE GPI	AS1198
7	SPINDLE	DR BRASS	AS1567 -352
6	GLAND	DR BRASS	AS1567 -352
5	COVER – BONNET	GUNMETAL BRONZE	AS1565 C83600M
4	BODY	GUNMETAL BRONZE	AS1565 C83600M
3	LOCK NUT	DR BRASS	AS1567 -352
2	DISC NUT	DR BRASS	AS1567 -352
1	DISC	GUNMETAL BRONZE	AS1565 C83600M

PVA PROMET VALVES AUSTRALIA
 1A Green Road Woodville West SA 5011
 www.prometvalves.com promet@prometvalves.com
 T: 08 8268 1777 ABN 47096 425 697 F: 08 8268 1711

FIG No **T2** BRONZE GLOBE VALVE CLASS 21
 FLANGED PN 20